

# HS-101B-HD Technical Data Sheet

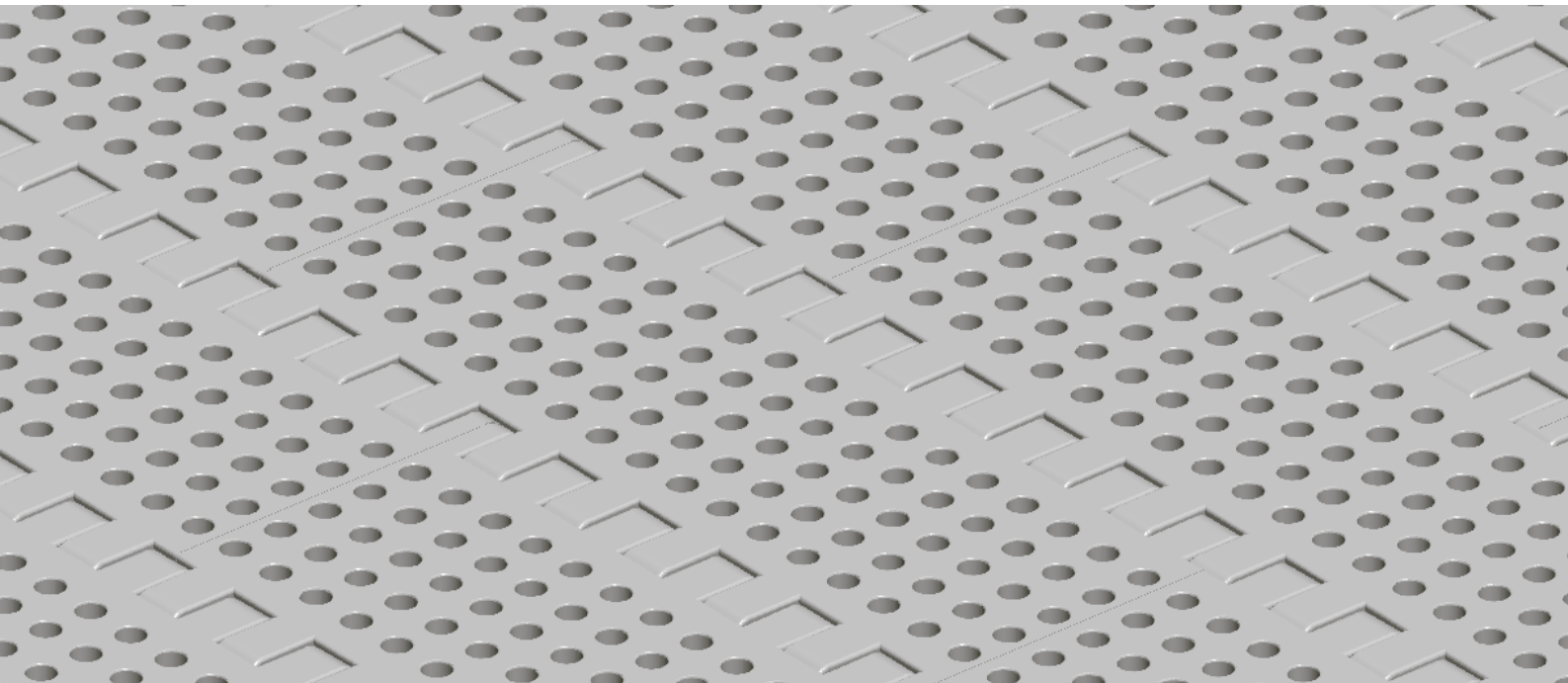

Pitch: 50.8mm  
 Minimum Width: 152mm  
 Open Area: 17.1%  
 Approved: FDA  
 Rod: Ø 8.0mm  
 Flight: Yes  
 Side Guard: No  
 Curve: No

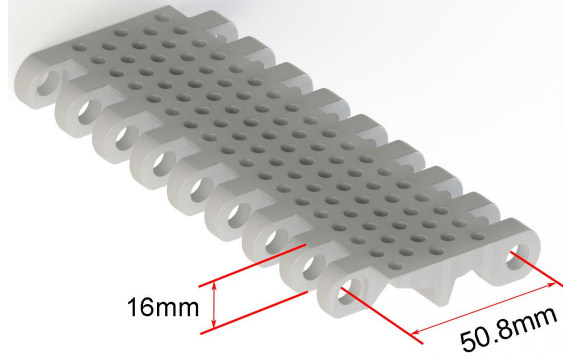

## Data

Belt Material	Belt Strength			Temperature		Belt Weight (Kg/M <sup>2</sup> )
	Straight		Curve	°C (min.)	°C (max.)	
	Kg/M(BW)	N/M(BW)				
Polypropylene	1340	13400	--	1	100	8.4
Polyethylene	1280	12800	--	-60	60	8.8
Acetal	1770	17700	--	-40	80	13.1
Nylon	1520	15200	--	1	180	11.8

BW – Belt Width

## Color Table

Polypropylene					Polyethylene					Acetal					Nylon				
W	G	N	DB	B	W	G	N	DB	B	W	G	N	DB	B	W	G	N	DB	B
●	●						●			●				●				●	

W-White, G-Gray, N-Nature, DB-Darkbrown, B-Blue

## Friction Table

Belt Material	Friction Wear strips & Products							
	UHMW	HDPE	Steel	Glass	SUS	Plastic	Cardboard	Aluminum
Polypropylene	0.32	0.24	0.15	0.09	0.13	0.08	0.15	0.25
Polyethylene	0.13	0.11	0.26	0.19	0.31	0.16	0.21	0.41
Acetal	0.11	0.09	0.27	0.16	0.26	0.15	0.19	0.28
Nylon	0.18	0.13	0.25	0.16	0.26	0.16	0.19	0.27

SUS – Stainless Steel

## Equivalent type with other Brand

Brand Name	Intralox	UNI	Rexnord	MCC	Habasit	KVP
Series & Type	200	OPB	6390	2000	H5000	620
	800	L-SNB	2010		M5100	
	850	MPB	2000			

The above content is only for reference.

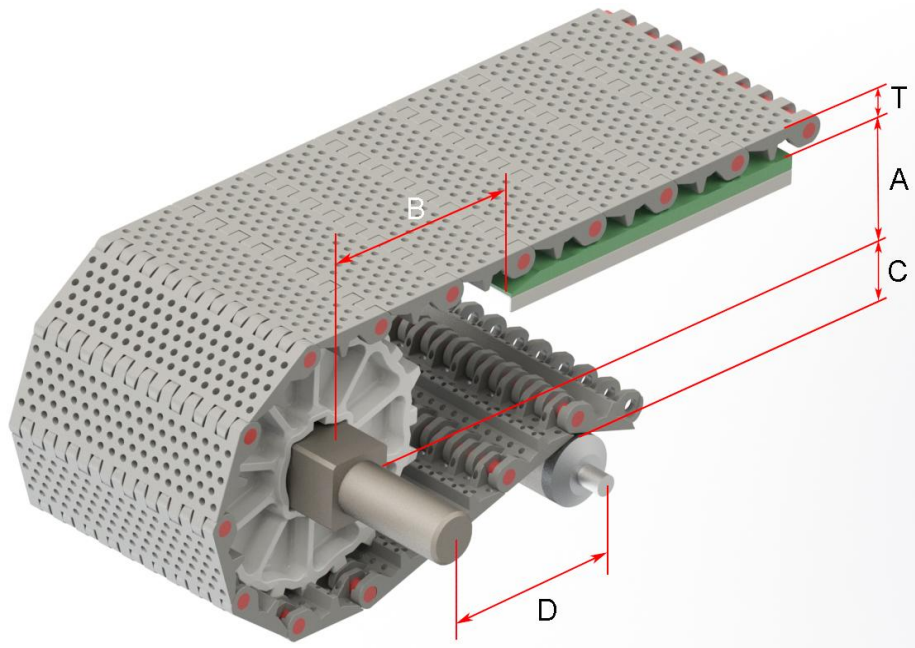

**Conveyor Frame Dimensions**

**Unit : mm**

No. Teeth	A ( Min. )	B ( Min. )	C ( Max. )	D ( Min. )	T
6	36.55	54.55	32.55	250	16
6/N	40.1	58.1	36.1	250	
8 / 8/N	53.65	71.65	49.65	250	
10 / 10/N	70.65	88.65	66.65	250	
12 / 12/N	87.4	105.4	83.4	300	

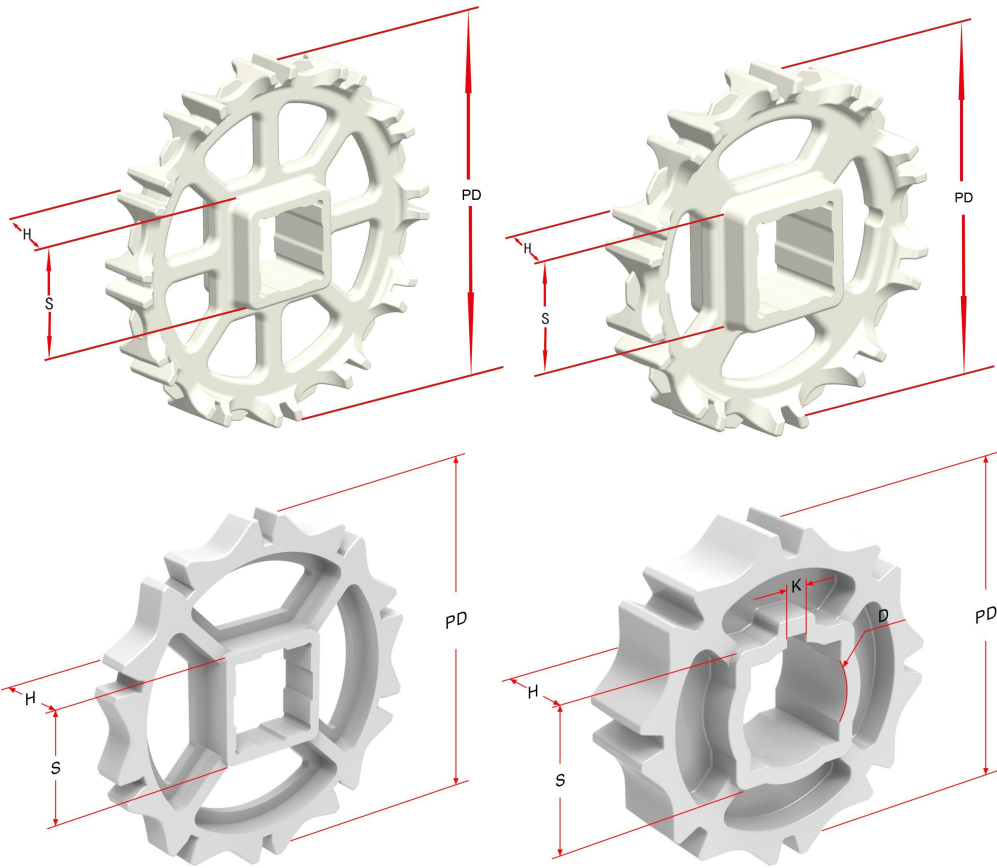

**Sprocket Dimensions**

**Unit : mm**

No. Teeth	PD	S	D	H	K
<b>6</b>	89.1	25.4/38.5/40.5	25.5/45.5	37	8X8
<b>6/N</b>	96.2	25.4/38.2	25.4/31.75	37	6.35X3.17
<b>8</b>	123.3	38.5/40.5	25.5/30.5	37	6.35X3.17
<b>8/N</b>	123.3	38.5/40.5	25.4/25.5/30.5/31.75	37	6.35X3.17
<b>10</b>	157.2	38.5/40.5	30.5	37	8X8
<b>10/N</b>	157.3	38.5/40.5/50.8	25.4/25.5/30.5/31.75/35/ 36.5/38.5/50.2/50.8	37	6.35X3.17
<b>12</b>	190.8	38.5/40.5/50.5/60.5	--	37	--
<b>12/N</b>	190.8	38.5/40.5/60.5	--	37	--