

## HS-1100EL Technical Data Sheet

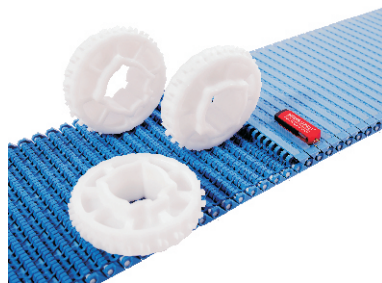
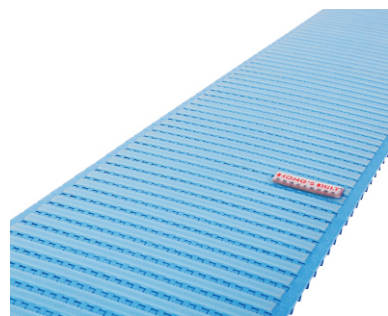
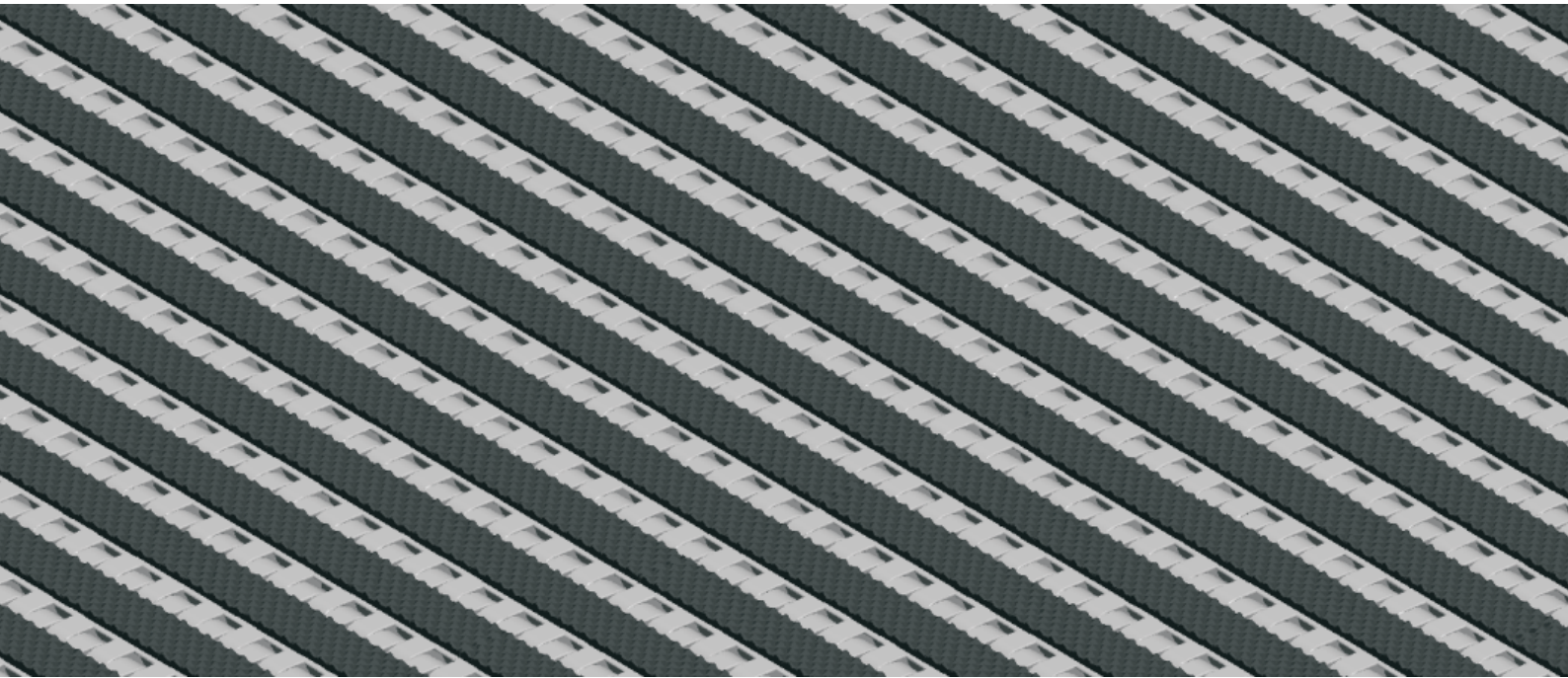

Pitch: 15.2mm Minimum Width: 208mm Open Area: 0% Approved: FDA Rod: Ø 4.9mm Flight: Yes Side Guard: No Curve: No	
---	--

## Data

Belt Material	Belt Strength			Temperature		Belt Weight (Kg/M <sup>2</sup> )
	Straight		Curve	°C (min.)	°C (max.)	
	Kg/M(BW)	N/M(BW)				
Polypropylene	1545	15450	--	1	70	6.0

BW – Belt Width

## Color Table

Polypropylene					Polyethylene					Acetal					Nylon				
W	G	N	DB	B	W	G	N	DB	B	W	G	N	DB	B	W	G	N	DB	B
●	●																		

W-White, G-Gray, N-Nature, DB-Darkbrown, B-Blue

## Friction Table

Belt Material	Friction Wear strips & Products							
	UHMW	HDPE	Steel	Glass	SUS	Plastic	Cardboard	Aluminum
Polypropylene	0.32	0.24	0.15	0.09	0.13	0.08	0.15	0.25
Polyethylene	0.13	0.11	0.26	0.19	0.31	0.16	0.21	0.41
Acetal	0.11	0.09	0.27	0.16	0.26	0.15	0.19	0.28
Nylon	0.18	0.13	0.25	0.16	0.26	0.16	0.19	0.27

SUS – Stainless Steel

## Equivalent type with other Brand

Brand Name	Intralox	UNI	Rexnord	MCC	Habasit	KVP
Series & Type	1000		1500			
	1100					

The above content is only for reference.

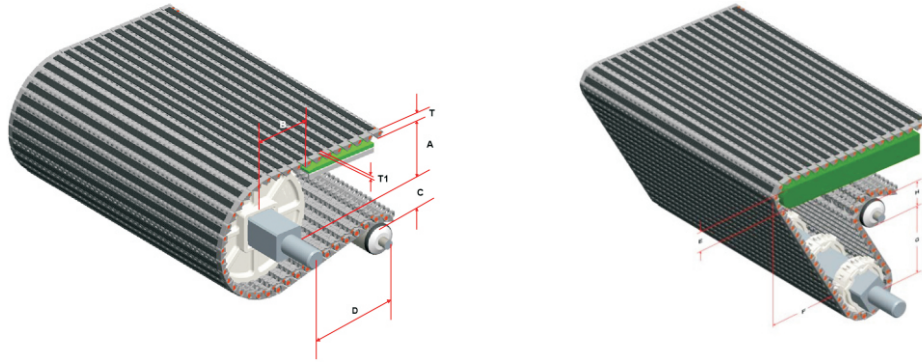

**Conveyor Frame Dimensions**

**Unit : mm**

No. Teeth	A (Min.)	B (Min.)	C (Max.)	D (Min.)	E (Min.)	H (Min.)	T
12	24.4	38.9	23.9	150	Ø 25	Ø 60	9.0
16	34.5	49	34	150	Ø 25	Ø 60	
24	54.5	69	54	150	Ø 25	Ø 60	
32	74	88.5	73.5	200	Ø 25	Ø 60	

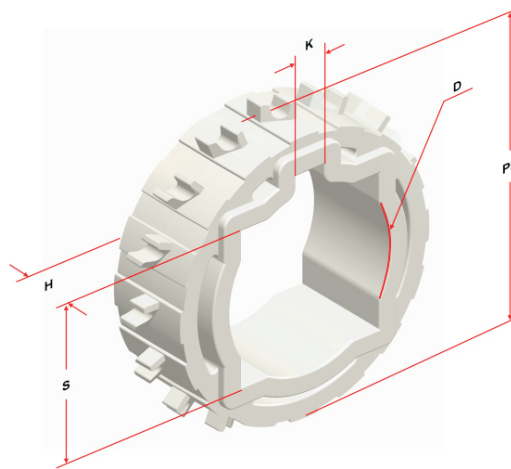

**Sprocket Dimensions**

**Unit: mm**

No. Teeth	PD	S	D	H	K
12	57.8	25.5	25.4	22.5	6.35X3.17
16	78	25.4/38.5/40.5	25.5/30.5/31.75/45.5	25	6.35X3.17
24	118	38.5/40.5	25.4/30.5/31.75/35.2/45.5/47.5	40	6.35X3.17
32	158	38.5/40.5	25.4/30.5/31.75/40.5	40	8X8