

HS-201A Technical Data Sheet

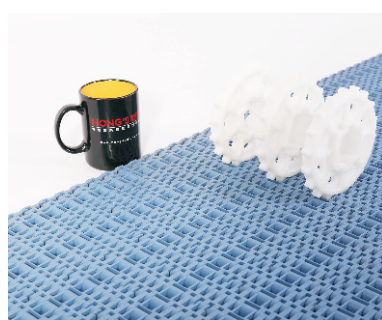

Pitch: 25.4mm
 Minimum Width: 75mm
 Open Area: 0%
 Approved: FDA
 Rod: Ø 5.8mm
 Flight: No
 Side Guard: No
 Curve: No

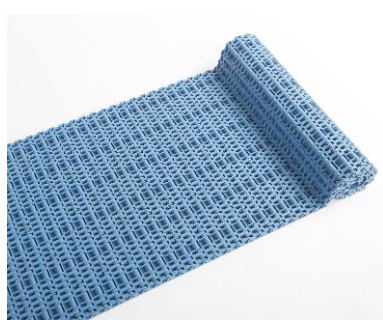
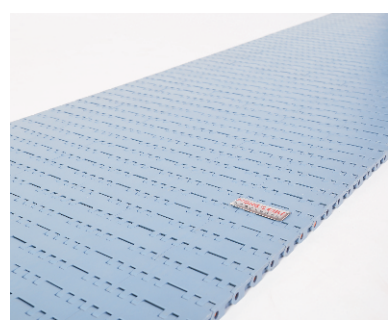
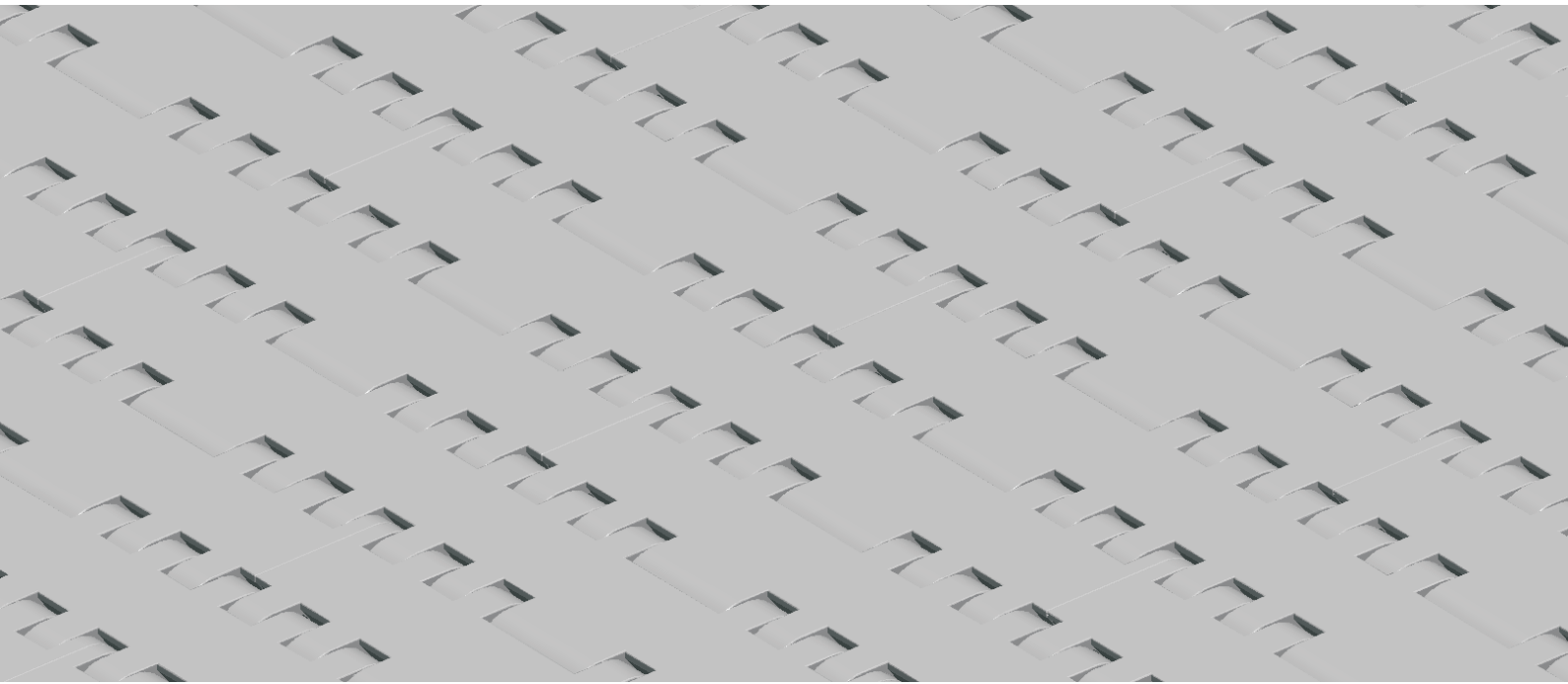
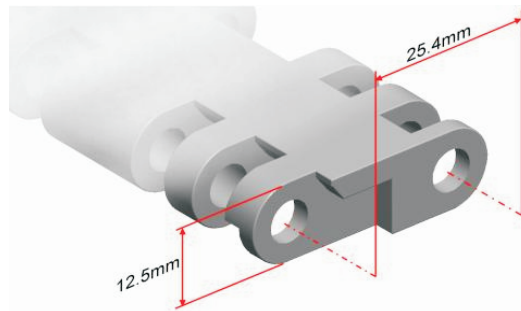

Data

Belt Material	Belt Strength		Curve	Temperature		Belt Weight (Kg/M ²)
	Straight			°C (min.)	°C (max.)	
	Kg/M(BW)	N/M(BW)				
Polypropylene	1270	12700	--	1	100	6.8
Polyethylene	1210	12100	--	-60	60	7.0
Acetal	1680	16800	--	-40	80	9.9
Nylon	1440	14400	--	1	180	8.6

BW – Belt Width

Color Table

Polypropylene					Polyethylene					Acetal					Nylon				
W	G	N	DB	B	W	G	N	DB	B	W	G	N	DB	B	W	G	N	DB	B
●	●						●			●				●				●	

W-White, G-Gray, N-Nature, DB-Dark brown, B-Blue

Friction Tables

Belt Material	Friction Wearstrips & Products							
	UHMW	HDPE	Steel	Glass	SUS	Plastic	Cardboard	Aluminum
Polypropylene	0.32	0.24	0.15	0.09	0.13	0.08	0.15	0.25
Polyethylene	0.13	0.11	0.26	0.19	0.31	0.16	0.21	0.41
Acetal	0.11	0.09	0.27	0.16	0.26	0.15	0.19	0.28
Nylon	0.18	0.13	0.25	0.16	0.26	0.16	0.19	0.27

SUS - Stainless Steel

Equivalent type with other Brand

Brand Name	Intralox	UNI	Rexnord	MCC	Habasit	KVP
Series & Type	100	SNB	7705		M2400	610
	1600/1650	CNB	1000		M2500	208CL
	200	OPB	1010		M2600	20835
	880/850	L-SNB	7700			13610

The above content is only for reference.

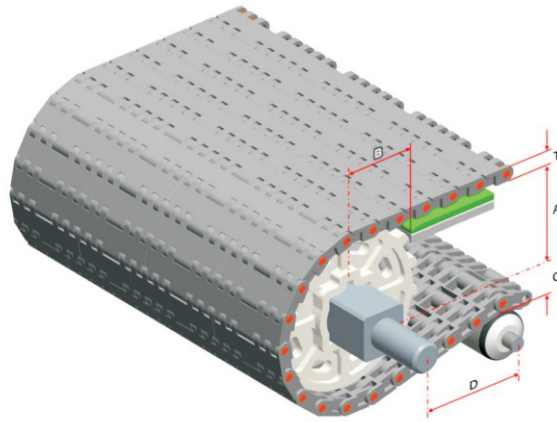

Conveyor Frame Dimensions

Unit : mm

No. Teeth	A (Min.)	B (Min.)	C (Max.)	D (Min.)	T
18	68.2	84.5	66	200	12.5

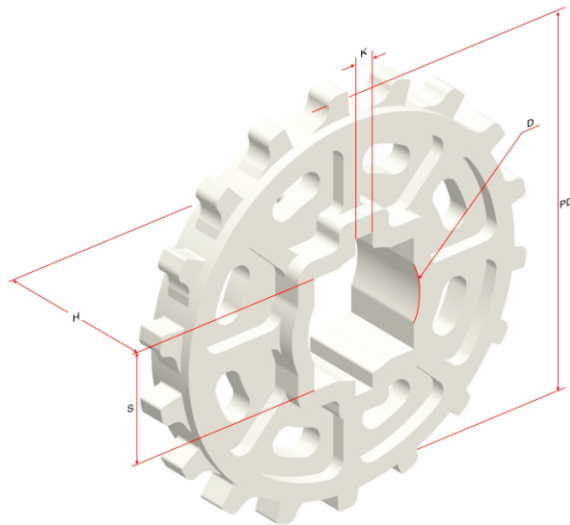

Sprocket Dimensions

Unit: mm

No. Teeth	PD	S	D	H	K
18	149	38.5/40.5	40.5/45.5	30	7X7