

HS-3000B Technical Data Sheet

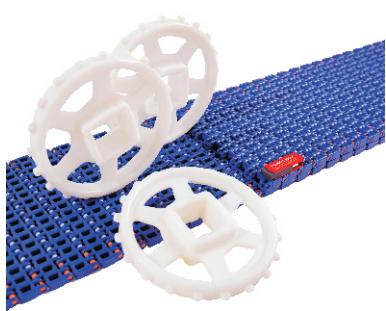
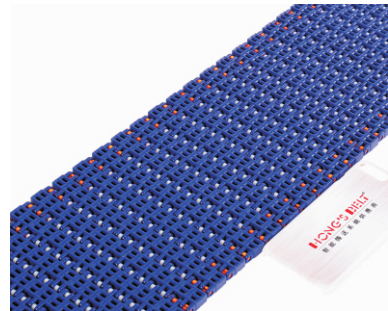
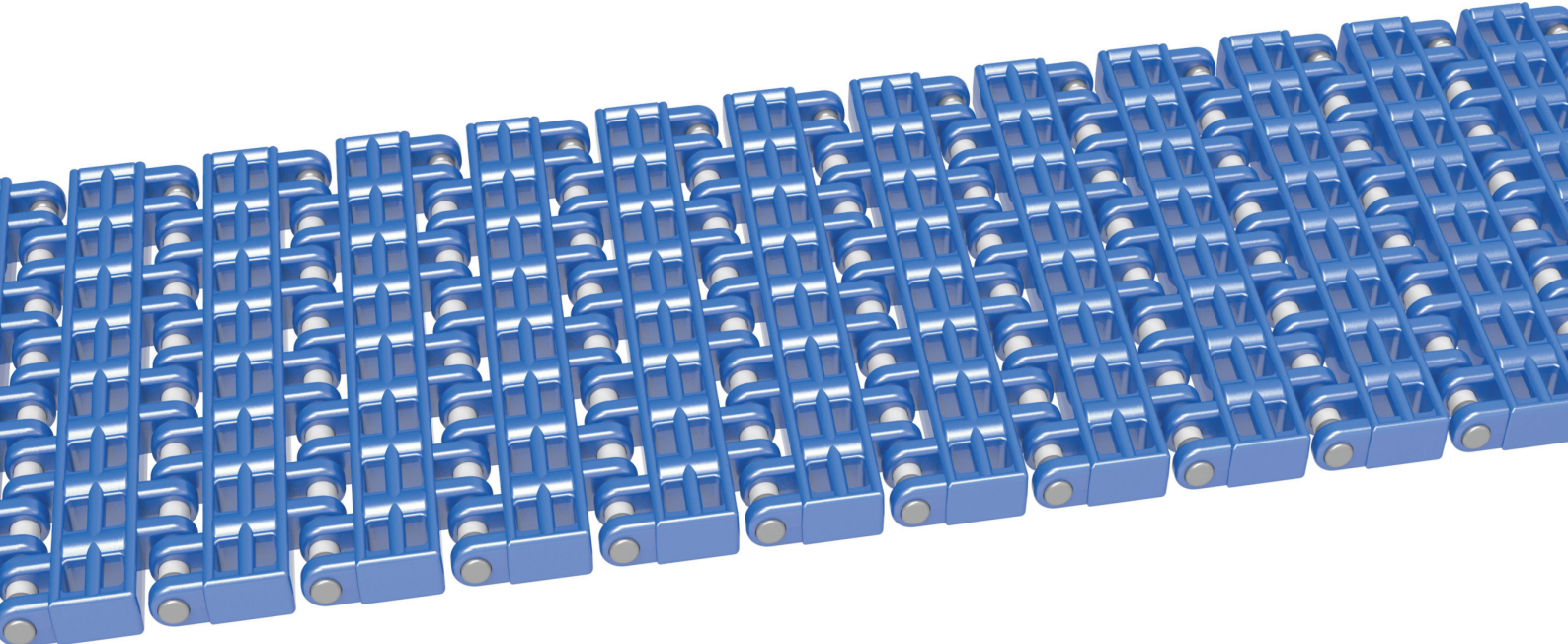

Pitch: 25.4 mm Minimum Width: 100mm Open Area: 25% Approved: FDA Rod: Ø 4.9mm Flight: No Side Guard: No Curve: No	
--	--

Data

Belt Material	Belt Strength				Temperature		Belt Weight
	Straight		Curve		°C (min.)	°C (max.)	(Kg/M ²)
	Kg/M(BW)	N/M(BW)	Kg/M(BW)	N/M(BW)			
Polypropylene	1010	10100	676	6760	1	100	4.0
Polyethylene	598	5980	476	4760	-60	60	4.3
Acetal	1540	15400	865	8650	-40	80	7.73

BW – Belt Width

Color Table

Polypropylene					Polyethylene					Acetal					Nylon				
W	G	N	DB	B	W	G	N	DB	B	W	G	N	DB	B	W	G	N	DB	B
●	●						●			●				●				●	

W-White, G-Gray, N-Nature, DB-Darkbrown, B-Blue

Friction Table

Belt Material	Friction Wear strips & Products							
	UHMW	HDPE	Steel	Glass	SUS	Plastic	Cardboard	Aluminum
Polypropylene	0.32	0.24	0.15	0.09	0.13	0.08	0.15	0.25
Polyethylene	0.13	0.11	0.26	0.19	0.31	0.16	0.21	0.41
Acetal	0.11	0.09	0.27	0.16	0.26	0.15	0.19	0.28
Nylon	0.18	0.13	0.25	0.16	0.26	0.16	0.19	0.27

SUS – Stainless Steel

Equivalent type with other Brand

Brand Name	Intralox	UNI	Rexnord	MCC	Habasit	KVP
Series & Type	2200	SNB	1200		M2500	610
	2400		7956		M3800	

The above content is only for reference.

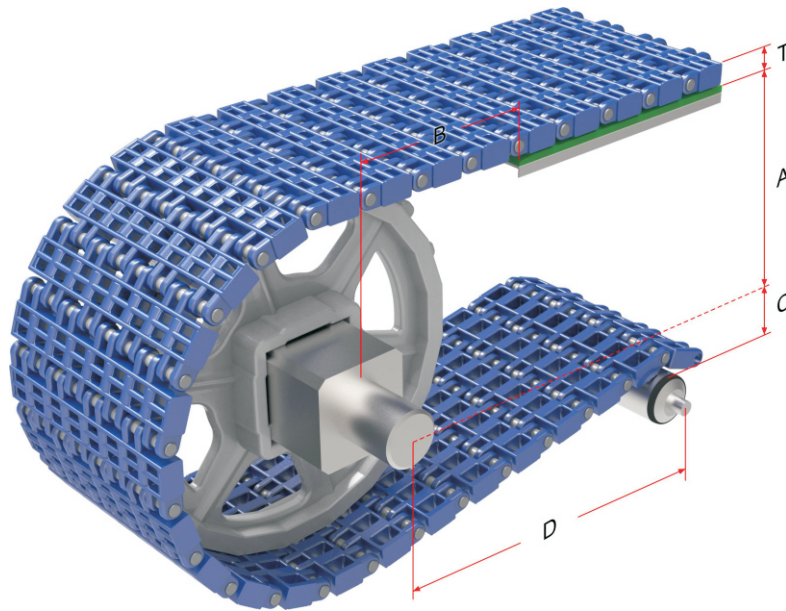

Conveyor Frame Dimensions

Unit : mm

No. Teeth	A (Min.)	B (Min.)	C (Max.)	D (Min.)	T
20	77.8	92.7	76.9	250	9.8

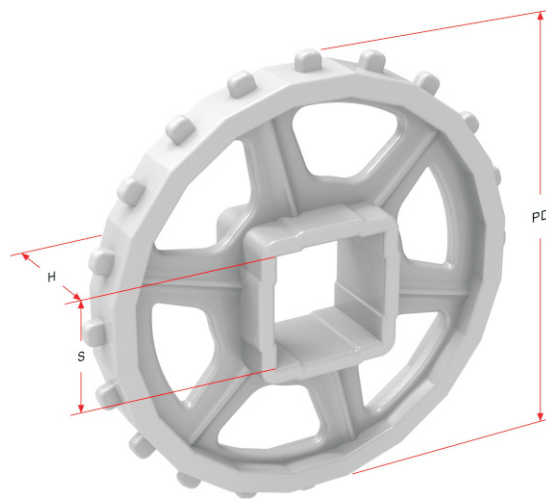

Sprocket Dimensions

Unit: mm

No. Teeth	PD	S	D	H	K
20	165.4	38.5/40.5	--	34	--