

HS-3600B Technical Data Sheet

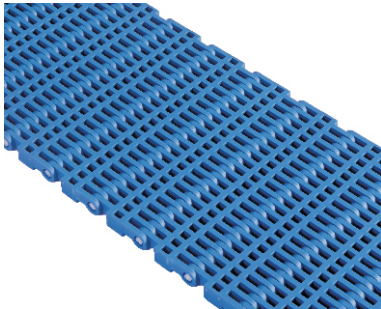
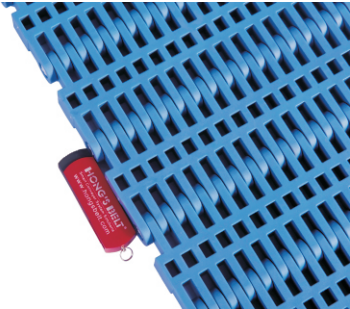
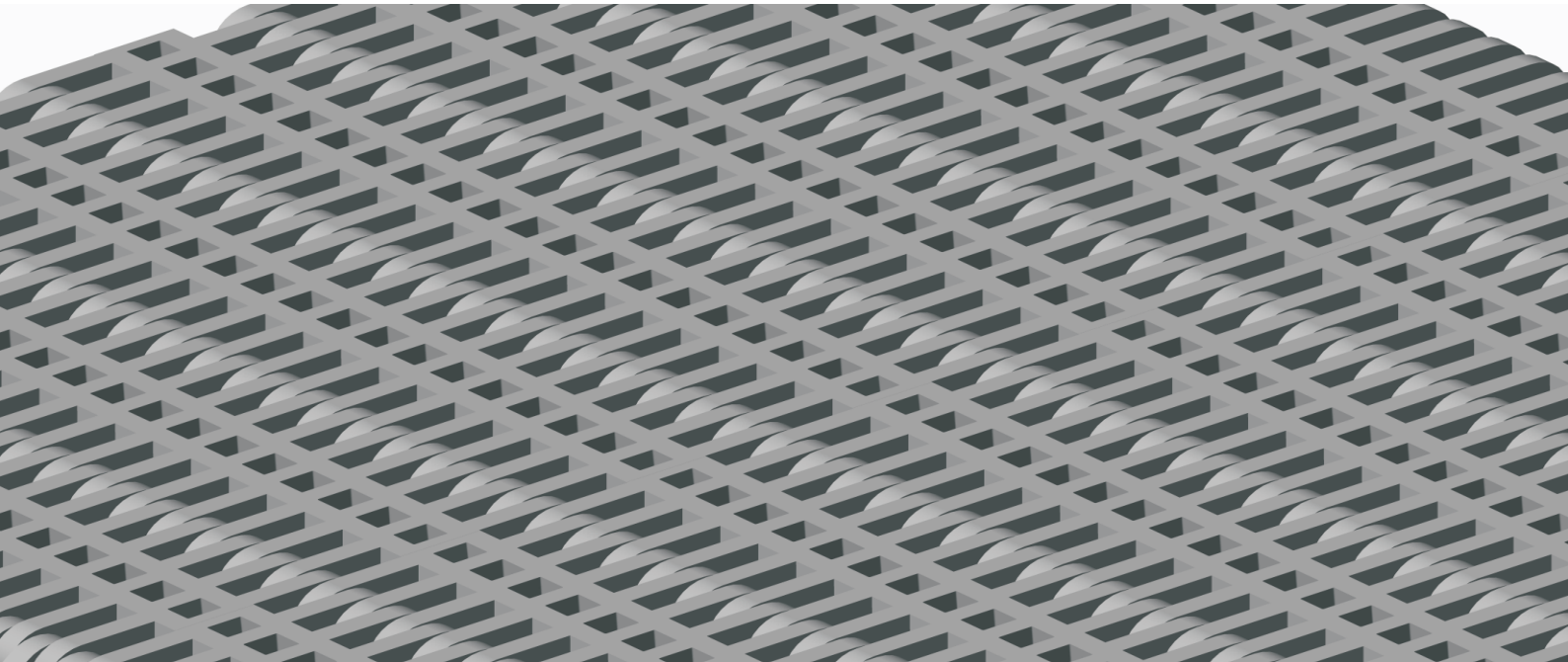

Pitch: 50mm Minimum Width: 200mm Open Area: 27% Approved: FDA Rod: Ø 5.8 mm Flight: Yes Side Guard: No Curve: No	
---	--

Data

Belt Material	Belt Strength			Temperature		Belt Weight
	Straight		Curve	°C (min.)	°C (max.)	(Kg/M ²)
	Kg/M(BW)	N/M(BW)				
Polypropylene	1340	13400	--	1	100	8.0
Polyethylene	1280	12800	--	- 60	60	8.0
Acetal	1770	17700	--	- 40	80	12.0

BW – Belt Width

Color Table

Polypropylene					Polyethylene					Acetal					Nylon				
W	G	N	DB	B	W	G	N	DB	B	W	G	N	DB	B	W	G	N	DB	B
●	●						●			●				●				●	

W-White, G-Gray, N-Nature, DB-Dark brown, B-Blue

Friction Table

Belt Material	Friction Wear strips & Products							
	UHMW	HDPE	Steel	Glass	SUS	Plastic	Cardboard	Aluminum
Polypropylene	0.32	0.24	0.15	0.09	0.13	0.08	0.15	0.25
Polyethylene	0.13	0.11	0.26	0.19	0.31	0.16	0.21	0.41
Acetal	0.11	0.09	0.27	0.16	0.26	0.15	0.19	0.28
Nylon	0.18	0.13	0.25	0.16	0.26	0.16	0.19	0.27

SUS – Stainless Steel

Equivalent type with other Brand

Brand Name	Intralox	UNI	Rexnord	Scanbelt	Habasit	KVP
Series & Type	--	--	--	S.50-100	--	--

The above content is only for reference.

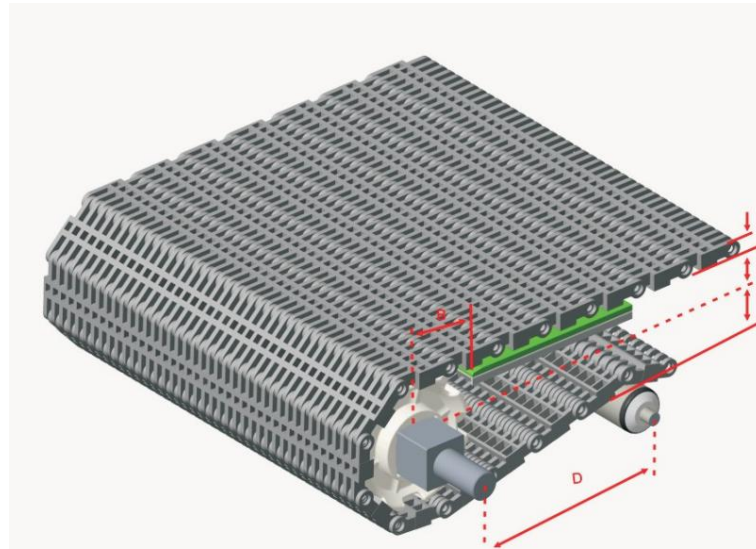

Conveyor Frame Dimensions

Unit : mm

No. Teeth	A (Min.)	B (Min.)	C (Max.)	D (Min.)	T
8	54.6	72.6	50.6	200	16
10	70.5	88.5	66.5	200	
12	86.6	104.6	82.6	200	

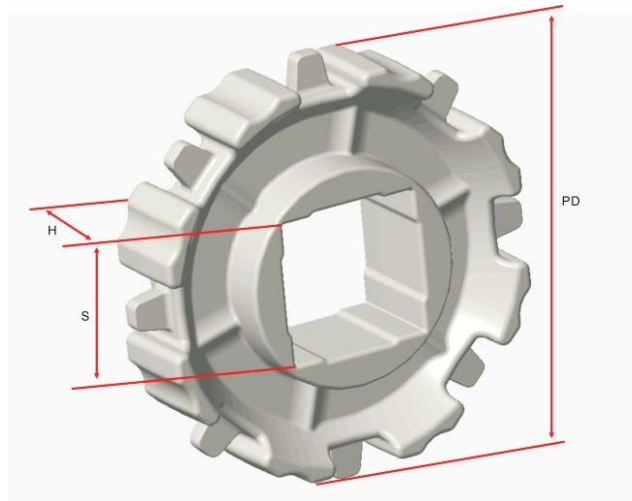

Sprocket Dimensions

Unit: mm

No. Teeth	PD	S	D	H	K
8	125.2	40.5	--	33.8	--
10	157	40.5	--	33.8	--
12	189.2	38.5/40.5	30.5	33.8	8X8