

HS-500A-N Technical Data Sheet

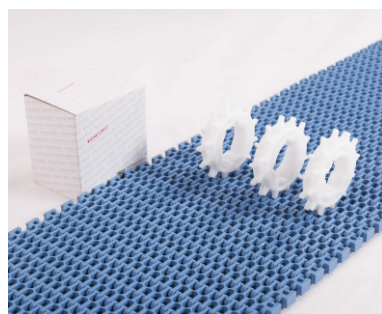
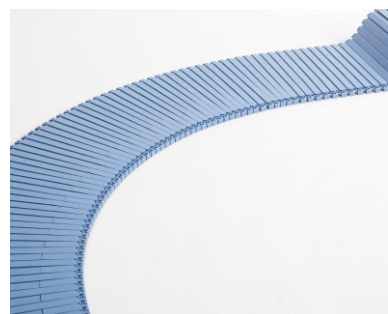
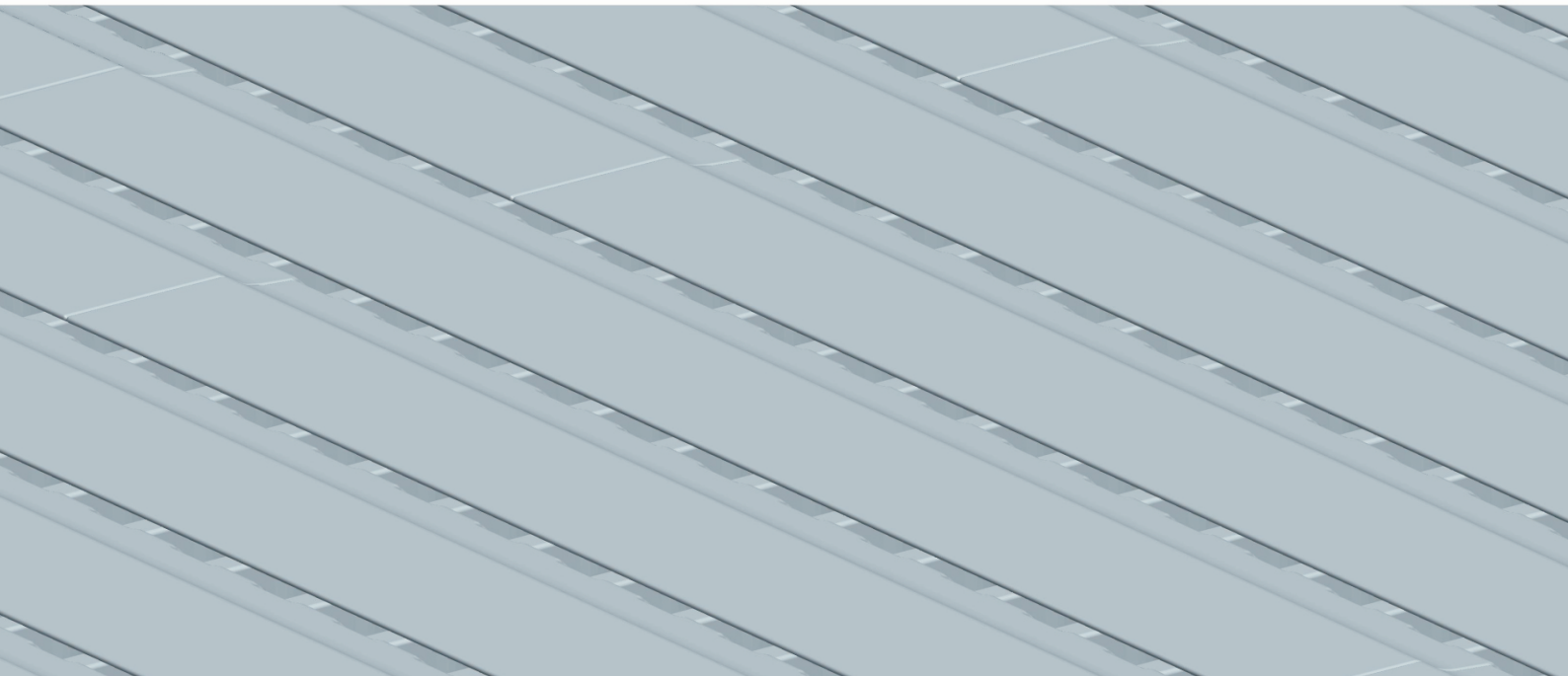

<p>Pitch: 25 mm</p> <p>Minimum Width: 305mm</p> <p>Open Area: 0%</p> <p>Approved: FDA</p> <p>Rod: Ø 4.5mm</p> <p>Flight: No</p> <p>Side Guard: No</p> <p>Curve: Yes</p>	
---	--

Data

Belt Material	Belt Strength				Temperature		Belt Weight
	Straight		Curve		°C (min.)	°C (max.)	(Kg/M ²)
	Kg/M(BW)	N/M(BW)	Kg/M(BW)	N/M(BW)			
Acetal	1700	17000	170	1700	- 40	80	11.0

BW – Belt Width

Color Table

Polypropylene					Polyethylene					Acetal					Nylon				
W	G	N	DB	B	W	G	N	DB	B	W	G	N	DB	B	W	G	N	DB	B
●	●						●			●				●					●

W-White, G-Gray, N-Nature, DB-Dark brown, B-Blue

Friction Table

Belt Material	Friction Wear strips & Products							
	UHMW	HDPE	Steel	Glass	SUS	Plastic	Cardboard	Aluminum
Polypropylene	0.32	0.24	0.15	0.09	0.13	0.08	0.15	0.25
Polyethylene	0.13	0.11	0.26	0.19	0.31	0.16	0.21	0.41
Acetal	0.11	0.09	0.27	0.16	0.26	0.15	0.19	0.28
Nylon	0.18	0.13	0.25	0.16	0.26	0.16	0.19	0.27

SUS – Stainless Steel

Equivalent type with other Brand

Brand Name	Intralox	UNI	Rexnord	MCC	Habasit	KVP
Series & Type	2200	SNB	1200		M2500	610
	2400		7956		M3800	

The above content is only for reference.

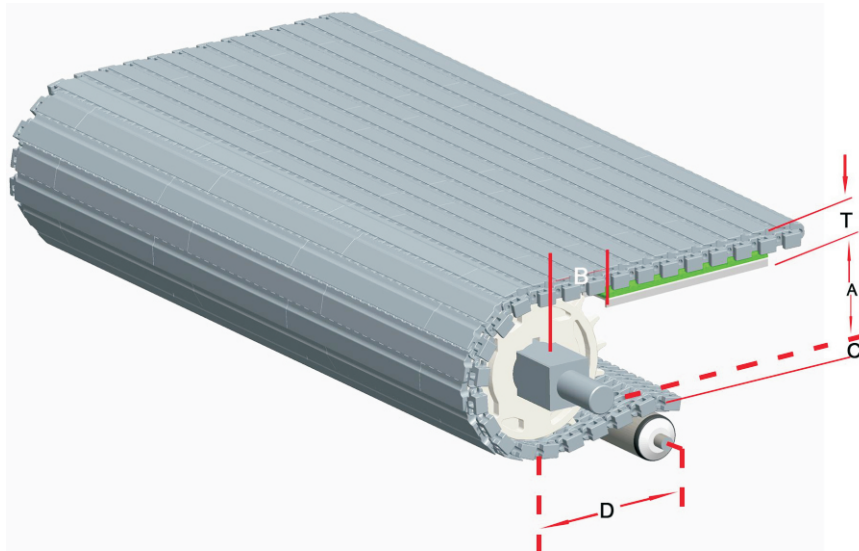

Conveyor Frame Dimensions

Unit : mm

No. Teeth	A (Min.)	B (Min.)	C (Max.)	D (Min.)	T
12	41.8	60	37.6	200	16.4
18	65.8	84	61.6	200	
24	91.8	110	87.6	250	

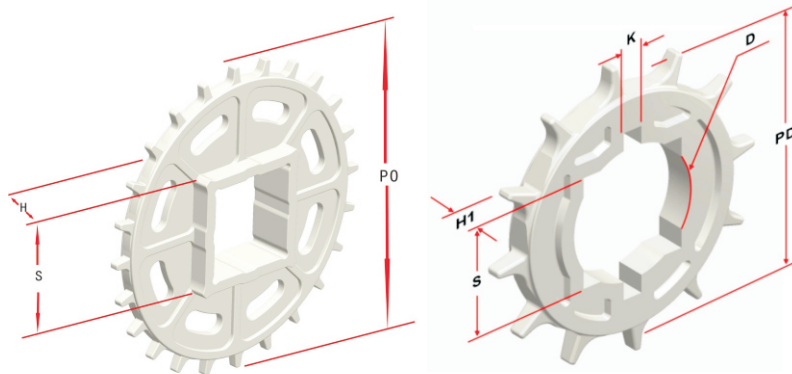

Sprocket Dimensions

Unit: mm

No. Teeth	PD	S	D	H1	H2	K
12	100	25.4/38.5/39/40.5	25.4/28/30.5/35.5/40.5/46.5/47.5	18	--	7X7
18	148	38.5/40.5	25.4/25.5/30.5/31.75/35.2/36.5/40.5/45.5/47.5	18	--	8X8
24	200	38.5/40.5/50.5/60.5	--	30	--	--

Design Guide Summary

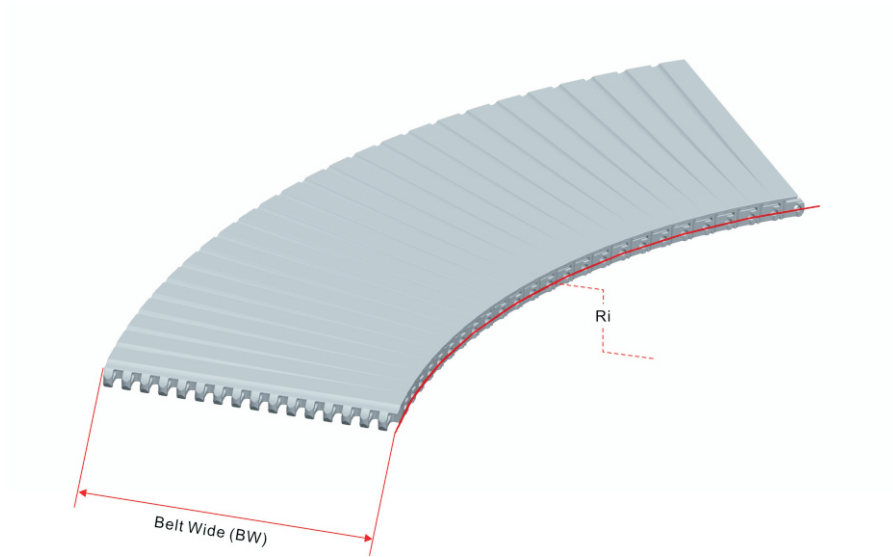

- ⌘ The minimum turning radius (inside) is 2.2 times of belt width under all feasible belt Width, 2.5 times of belt width is the most optimal.
- ⌘ The minimum straight run section near driving shaft and idling shaft of Radius belt must be 2 times of the belt width in length.
- ⌘ The minimum straight run section between two turns of opposing direction must be 2 times of the belt width in Length.

Guide Rail & Wear Strips

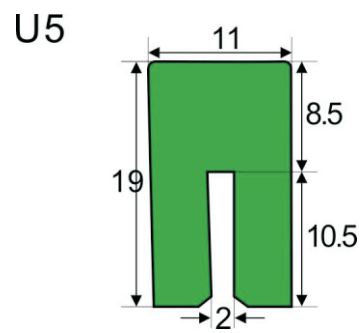
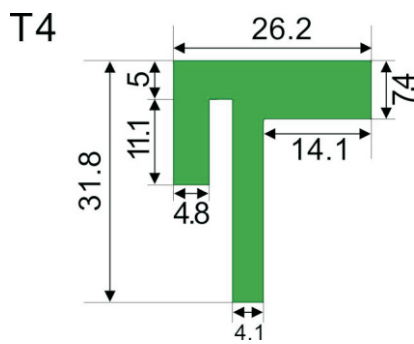

- ⌘ We have different kinds of guide rail and wear strips for your choice; for more information, please consult our sales team.